

Smart Positioner YT-2500

Product Number: YT-2500 (specify your requirement)

Model	Motion Type	Acting Type	Explosion Proof	Lever Type		Connection Type	Communication	Option	Fail Option
				Linear	Rotary				
YT-2500	L Linear	S Single	n Non-Explosion	1 10~40mm	1 M6 × 34L	1 PT	0 NONE	0 NONE	F Fail Freeze
	R Rotary	D Double	i Ex ia IIC T6/T5	2 20~70mm	2 M6 × 63L	2 NPT	2 + HART	1 + PTM	S Fail Safe
				3 50~100mm	3 M8 × 34L			2 + L/S(Mechanical Type)	
				4 100~150mm	4 M8 × 63L			3 + L/S(Proximity Type)	
						5 NAMUR		4 + PTM+L/S(Mechanical Type)	



YT-2500R



YT-2500R+L/S

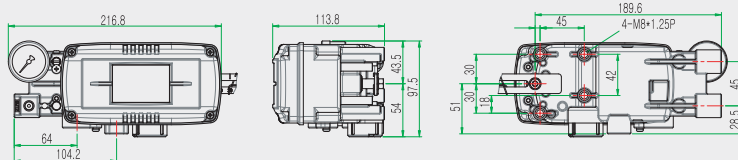

Item · Type	YT-2500L	YT-2500R
Input Signal	4~20mA DC	
Supply Pressure	1.4 ~ 7kgf /cm ² (0.14~0.7MPa)	
Stroke	10~150mm	0 ~ 90°
Impedance	Max.460Ω / 20mA DC	
Air Connection	PT(NPT)1/4	
Gauge Connection	PT(NPT)1/8	
Conduit	PF1/2 (G1/2)	
Repeatability	±0.3% F.S.	
Ambient Temp.	Operating Temp.	-30°C ~ 85°C (-22~185° F)
	Explosion Temp.	-40~60°C(T5)/-40~40°C(T6)
Linearity	±0.5% F.S.	
Hysteresis	±0.5% F.S.	
Sensitivity	±0.2% F.S.	
Air Consumption	0.01LPM(sup=1.4k)	
Flow Capacity	50LPM	
Output Characteristics	Linear, EQ%, Quick Open user set (16 Point)	
Material	Aluminum Diecasting	
Protection	IP66	
Explosion Proof type	Ex ia IIC T6/T5	
Weight	1.5kg (3.3lb)	

YT-2500 Smart Valve Positioner accurately controls valve stroke, according to input signal of 4-20mA being delivered from controller.

- Fail freeze function
- Near zero air consumption level
- HART communication
- Auto calibration
- PD control
- 4 buttons for local control
- LCD display
- Feedback signal
- Limit switches (option)

Bracket, Lever

YT-1000R Bracket Series

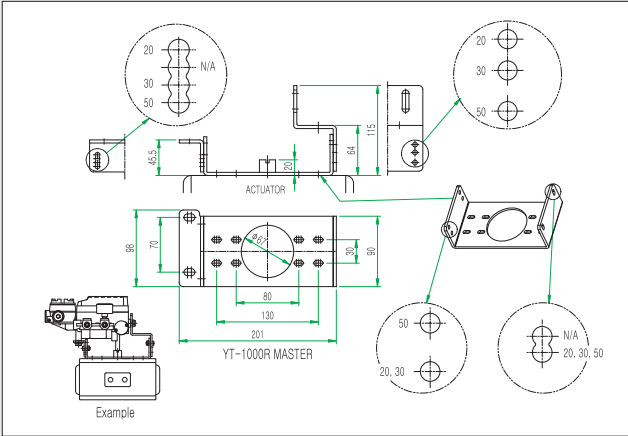

YT-1200R Bracket Series

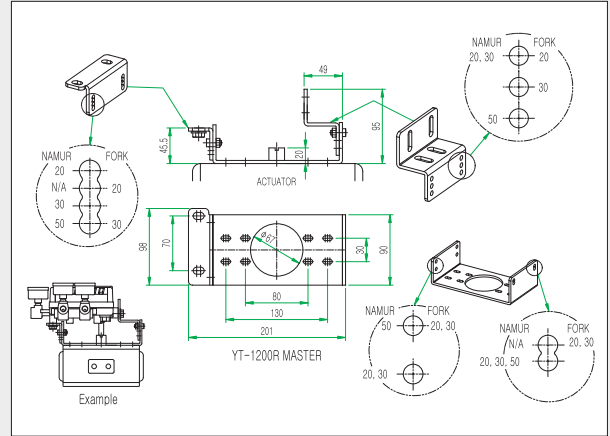

YT-1300R & YT-1350R & YT-2300R & YT-2350R & YT-2400R & YT-2500R Bracket Series

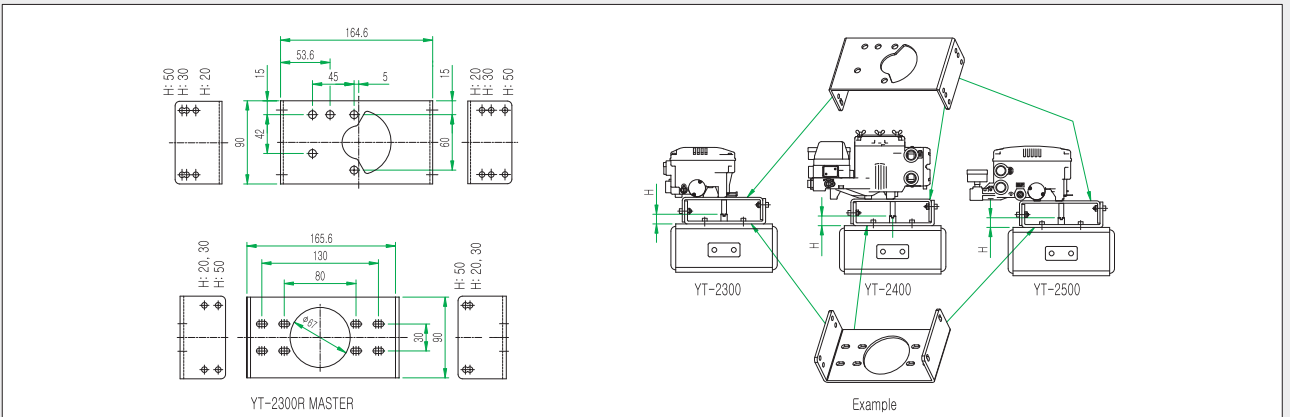

YT-1000L & YT-1200L & YT-2300L & YT-2500L Namur Bracket Series

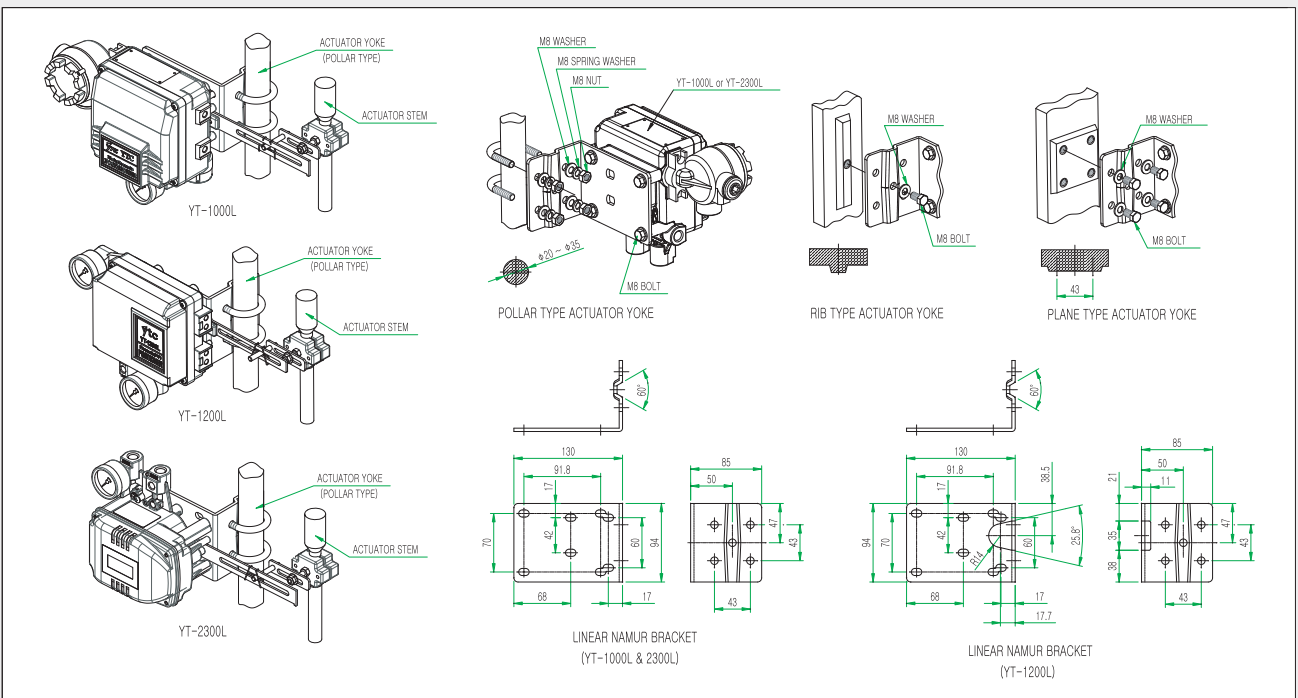

Bracket, Lever

Lever Series

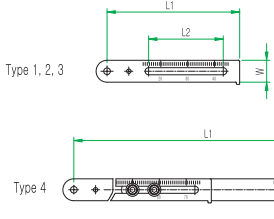

Type 1, 2, 3

Lever Type	Stroke(mm)	L1(mm)	L2(mm)	W(mm)
1	10~40	121.2	68.2	20.0
2	30~70	195.0	120.0	
3	60~100	277.0	122.0	
4	110~150	400.0	122.0	

YT-1000 & 1200 Linear Type

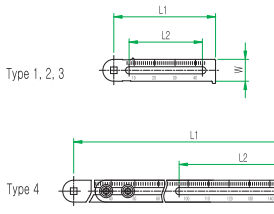

Type 1, 2, 3

Lever Type	Stroke(mm)	L1(mm)	L2(mm)	W(mm)
1	10~40	93.0	67.0	20.0
2	20~70	153.5	106.5	
3	50~100	214.0	117.0	
4	100~150	307.3	117.0	

YT-1300 & 1350 & 2300 & 2301 & 2350 & 2400 & 2500
& PTM-5V & 6V Linear Type

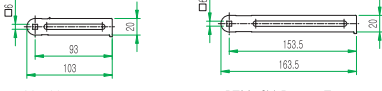

PTM-5V Rotary Type PTM-6V Rotary Type

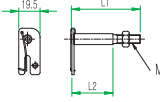

Lever Type	L1(mm)	L2(mm)	M
1	34	9	M6
2	63	37	
3	34	9	M8
4	63	37	

Rotary Type

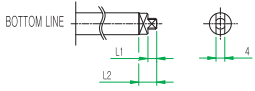

Model	L1(mm)	L2(mm)
YT-1000, 1200	7	11
YT-2300, 2400, 2500	4	8

Namur Type

YT-850 Bracket Series

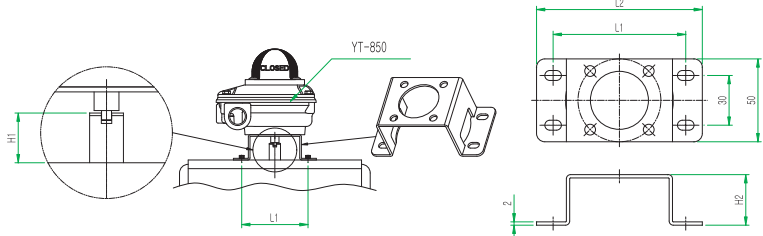

MODEL NO.	H1 (mm)	H2 (mm)	L1 (mm)	L2 (mm)	REMARK
ST-1	20	30.5	80	100	
ST-2	30	40.5			
ST-3	30	40.5	130	150	
ST-4	50	60.5			

YT-870 Bracket Series

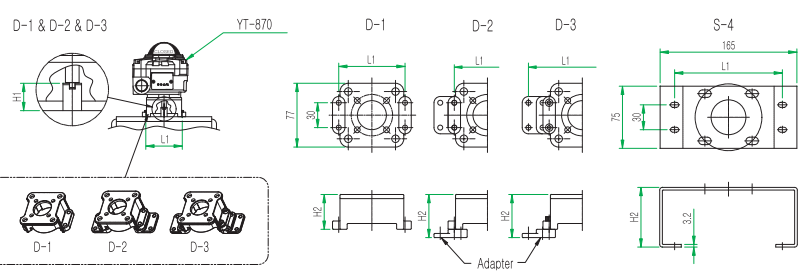

MODEL NO.	H1(mm)	H2 (mm)	L1 (mm)	REMARK
D-1	20	42	80	
D-2	30	52		
D-3	30	52		130
S-4	50	72		